

KLX-500-1U

Industrial DVI-D/VGA/KVM Signal Extender via LAN



Extend HD DVI-D, Keyboard-Mouse, and audio over LAN on one industrial rack.

FEATURES

- Extends KVM operation by 500 feet via LAN (Cat5e/6 cables)
- Chainable for thousands of feet of extension
- Supports DVI monitors
- Integrated VGA-to-DVI source converter
- Supports full USB Keyboard-Mouse emulation
- Audio input and output
- Supports dual Keyboard, Video, Mouse control operation with KVM devices
- Supports 1080p up to 1920x1080 resolution at 60Hz
- Plug-and-Play ready; industrial enclosure

APPLICATIONS

- Presentations
- Conferences
- Surveillance
- Remote monitoring
- Healthcare
- Education
- Video correspondence
- Hotels
- Restaurants and digital menus
- Government
- Military

WHAT IS KLX-500-IU?

The KLX-500-IU is an industrial-strength DVI-D with VGA input support and KVM signal extender capable of transmitting 1080p HD video to displays up to 500 feet away via CAT5e/6 cables over LAN. The KLX-500-IU also offers full USB keyboard, video, and mouse operation extension for local and remote real-time system management; great for supervising and managing projects from the convenience of your personal workstation.

KLX-500-IU is plug-and-play ready for easy set-ups, is plug-and-play ready for easy set-ups, and chainable with other KLX extenders to connect with workstations over 500 feet away. A simple yet powerful system enhancing tool for any working environment. Don't let distance limit your systems: go further with the KLX-500-IU.

APPLICATION DIAGRAM

Smart-AVI KLX-500-1U

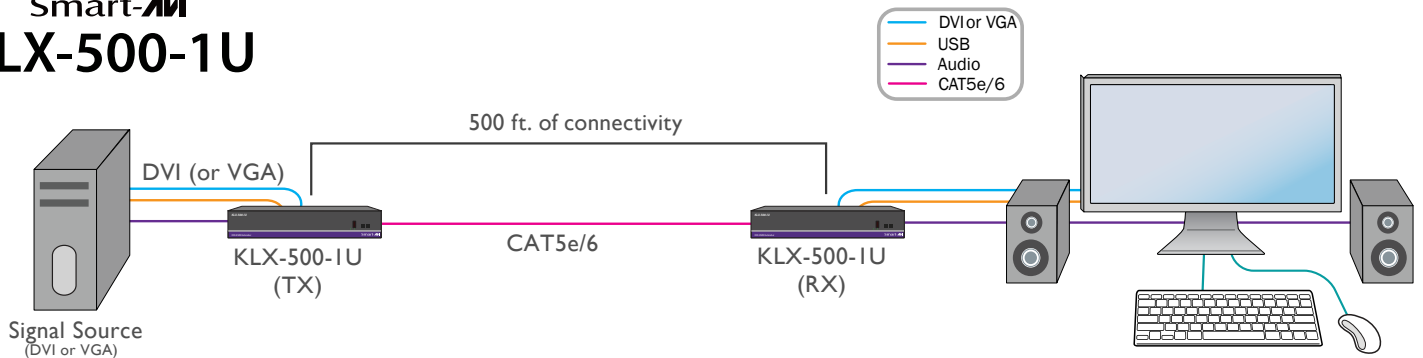

KLX-500-IU (TX) Front



KLX-500-IU (TX) Back

SPECIFICATIONS

Video	
Format	DVI-D
HDTV Resolutions	480p, 720p, 1080i, 1080p/60Hz/48bit
TV Resolution	480i
Input Interface (TX)	DVI-I, 2 USB Type A Female & 1 USB Type B
Output Interface (RX)	DVI-I, 2 USB Type A Female
Input Cable Length (TX)	Up to 40 ft.
Output Cable Length (RX)	Up to 40 ft.
Audio	
Format	Stereo
Input Interface	3.5 mm Jack Socket (Female)
Output Interface	3.5 mm Jack Socket (Female)

System	
Interface	RJ-45
Cable Requirements	CAT 5/5e/6
Maximum Length	500 ft.
Other	
Power	External 100-240 VAC
Dimensions TX & RX	17.125"W X 3.75"D X 2"H each
Weight TX & RX	1.2 lbs. each
Approvals	UL, CE, ROHS Compliant
Operating Temp.	41 to 122°F (5 to 50 °C)
Storage Temp.	32 to 149°F (0 to 65 °C)
Humidity	Up to 85%

ORDERING INFORMATION

Part No.	Description
KLX-500-1U-S	Industrial DVI, KVM Signal Extender. Includes:[KLX-500-1U-TX, KLX-500-1U-RX]



Designed and Manufactured in the USA

www.smartavi.com

Tel: 800.AVI.2131 • 818.503.6200 • 11651
Vanowen St. North Hollywood, CA. 91605

Smart-AVI
SMART AUDIO VIDEO INNOVATION